



**Aluminum Trailers**

# OPEN HAULERS

Got a car, truck or ATV to move? We can help!

## SMOOTH LOADER

Car Hauler

Shown with Optional Aluminum Deck



## AMT OATV

Open Quad

## AMCH

Car Hauler

Tapered Beavertail and 6' Long Ramps Are Standard



## OB1

Motorcycle Hauler

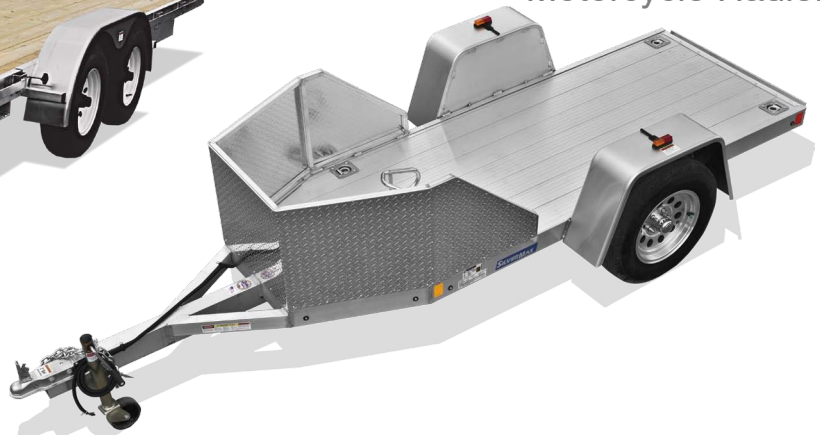

## AMCHDO

Deck Over

8' Long Ramps Are Standard



## OB2

Motorcycle Hauler

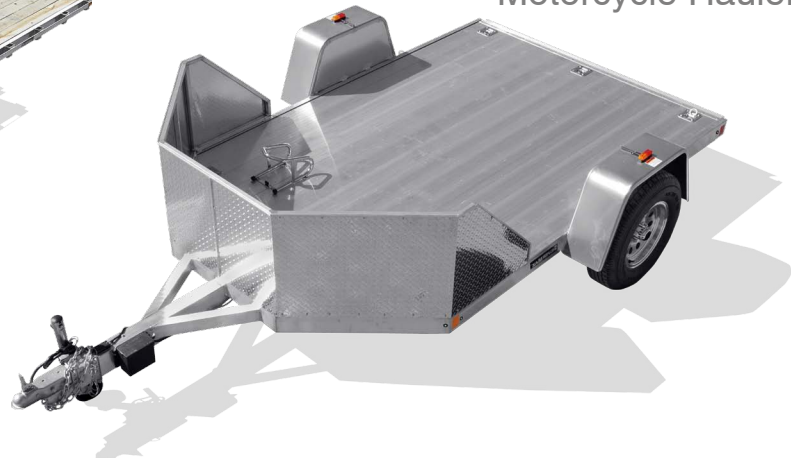



# OPEN HAULERS

## SMOOTH LOADER Car Hauler

The Smoothloader is available in a variety of configurations.

### Choices Include

- Wood or Aluminum Bed
- 3500, 5200 or 6000 lb. Axles
- Manual Tilt or Electric Tilt
- Lengths From 18' to 24'

For the **Smooth Loader** and **AMCH Deck Over**, you can add **Heavy Duty D-Rings** for additional flexibility in securing your loads!



2" Thick (nominal)  
Pine Plank Treated Floor

Removable  
Fenders

For fast and easy loading, nothing beats the Middlebury Trailers sleek and powerful Smooth Loader.

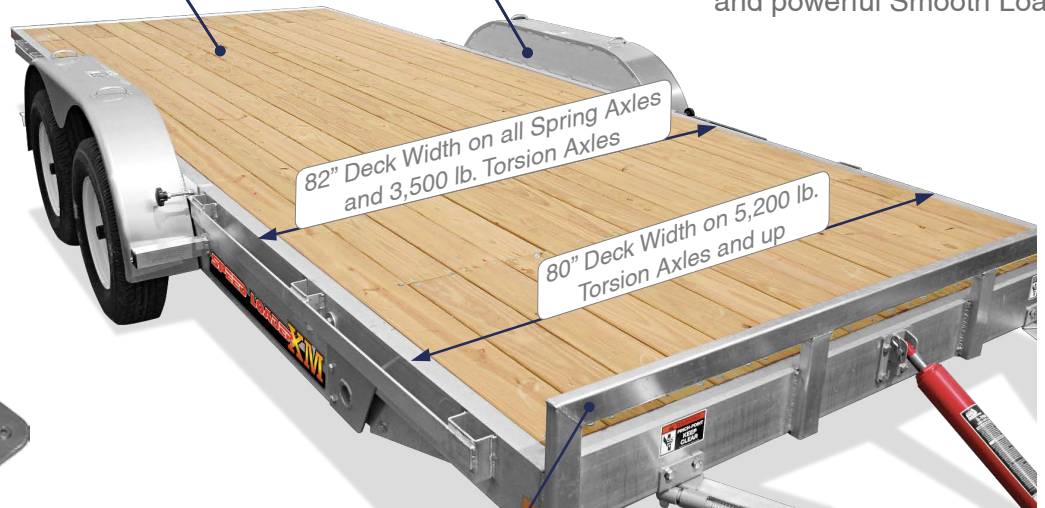

82" Deck Width on all Spring Axles  
and 3,500 lb. Torsion Axles

80" Deck Width on 5,200 lb.  
Torsion Axles and up

7" Tall Front Rail

## TILT AND GO!

No ramps to hassle with!

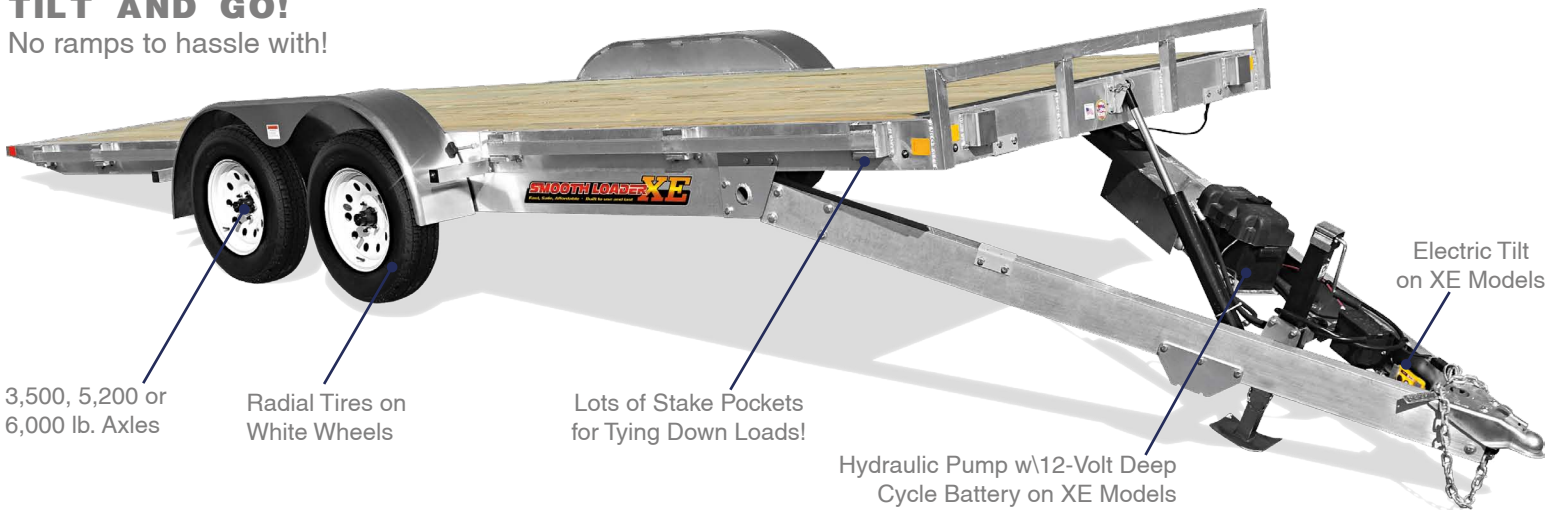

Electric Tilt  
on XE Models

3,500, 5,200 or  
6,000 lb. Axles

Radial Tires on  
White Wheels

Lots of Stake Pockets  
for Tying Down Loads!

Hydraulic Pump w/12-Volt Deep  
Cycle Battery on XE Models

Optional Aluminum Deck

7,000 lb. Tongue Jack

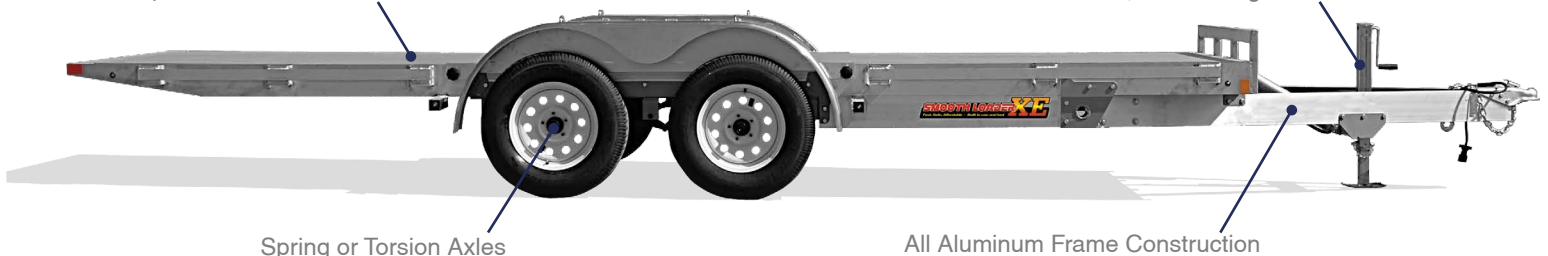

Spring or Torsion Axles

All Aluminum Frame Construction

### SMOOTH LOADER

XM Model = MANUAL TILT  
XE Model = ELECTRIC TILT



# AMCH Car Hauler

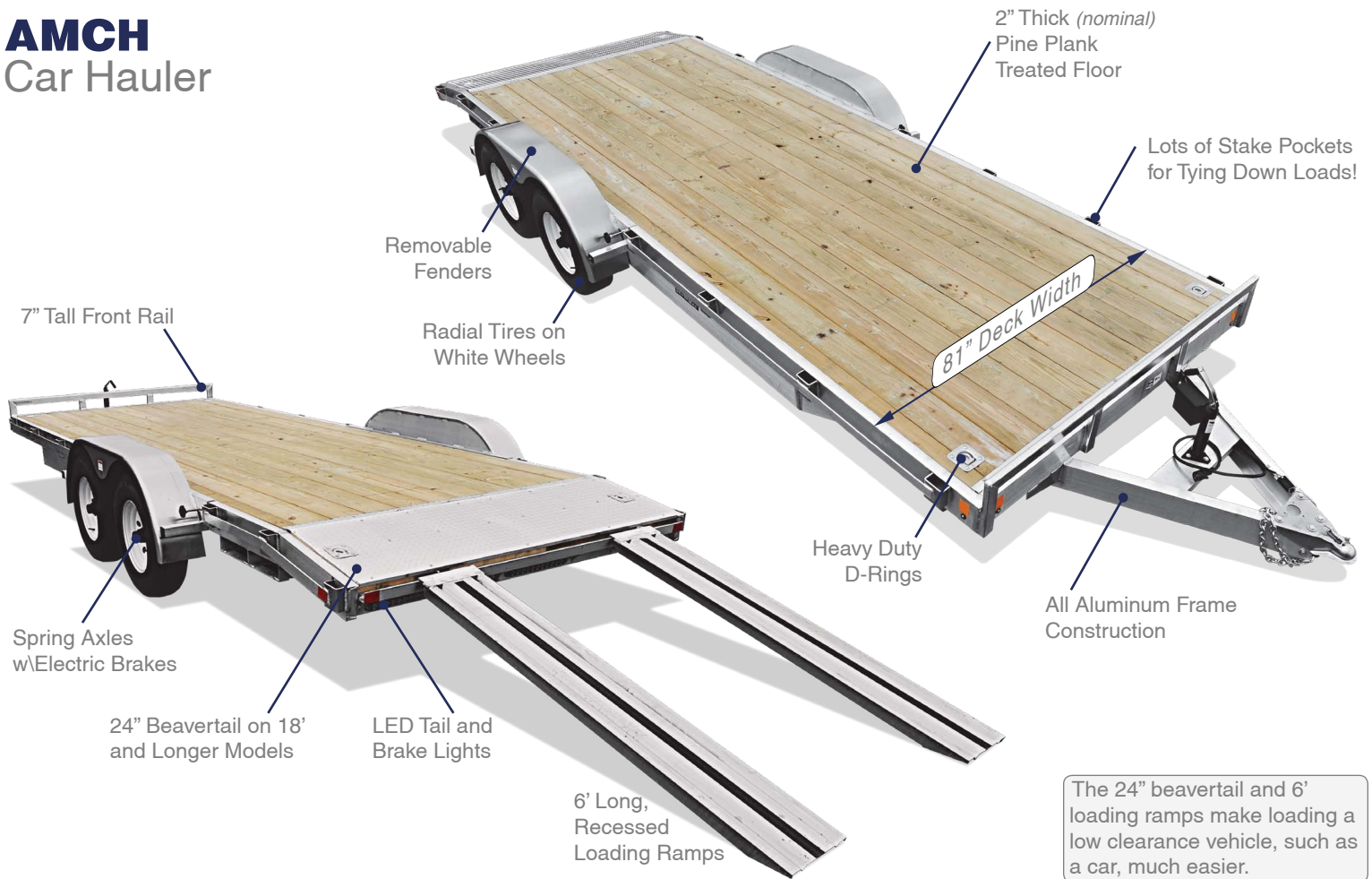

# ARCHDO Deck Over

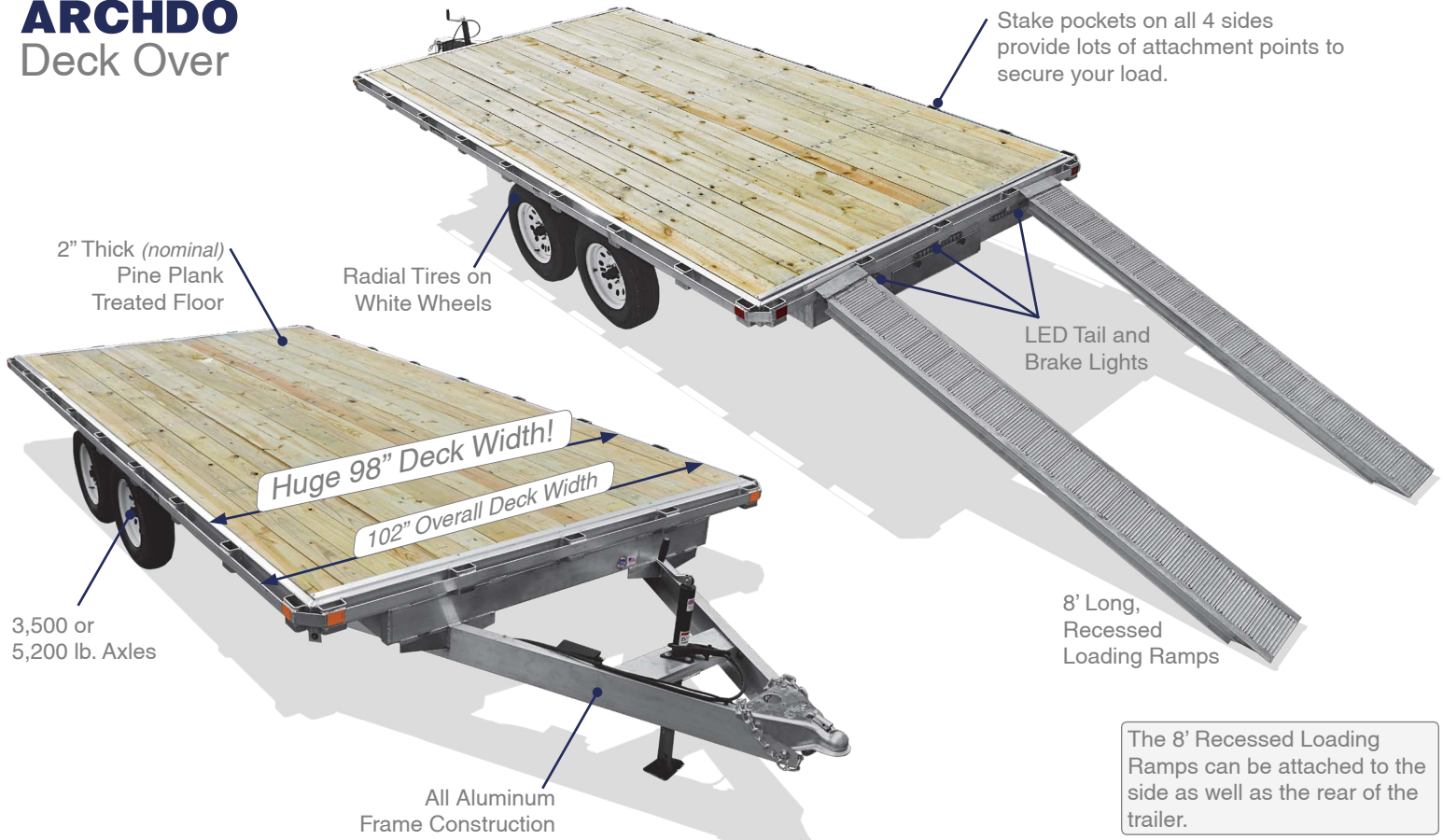

## OB1 Motorcycle Trailer

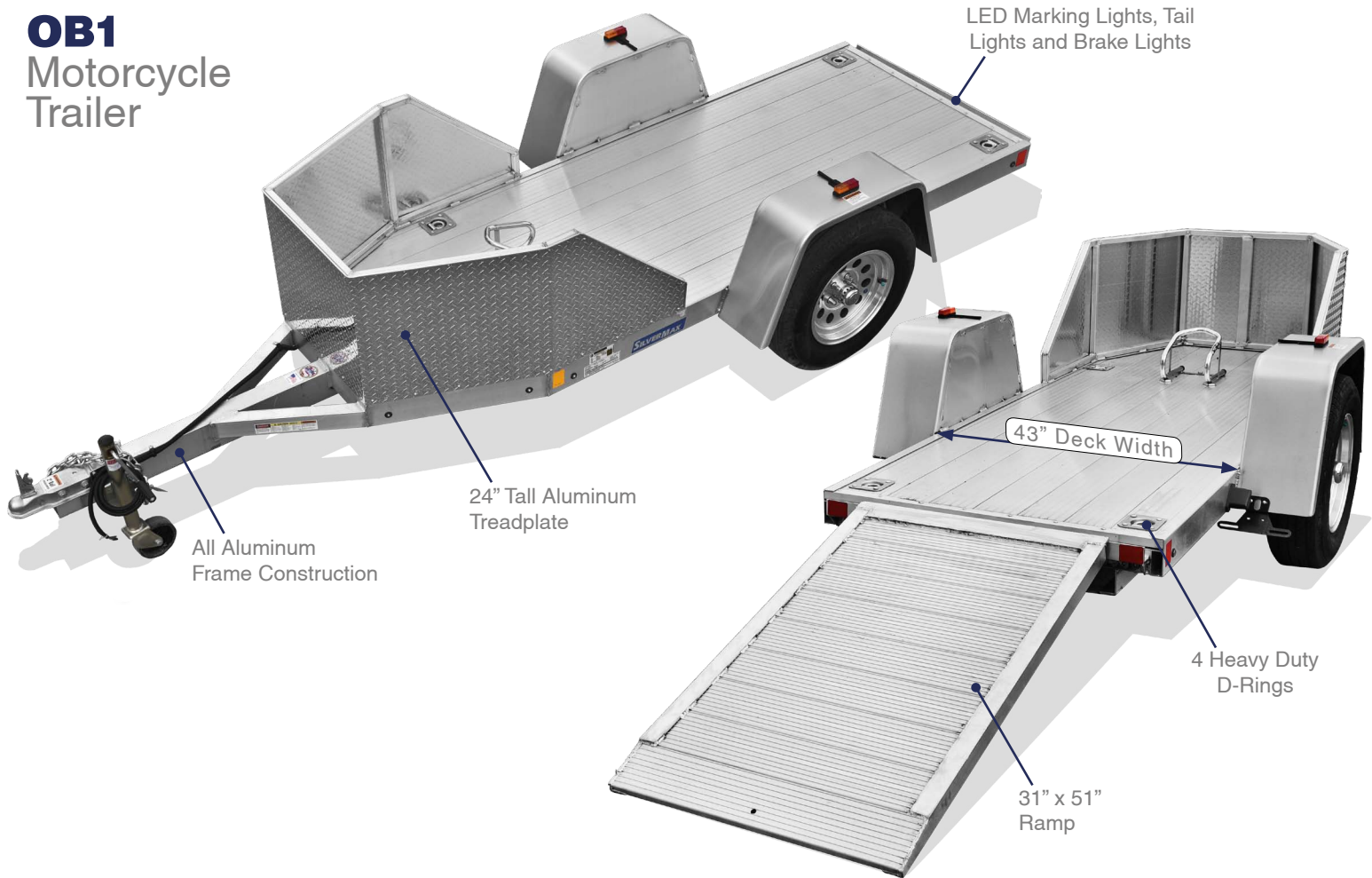

## OB2 Motorcycle Trailer

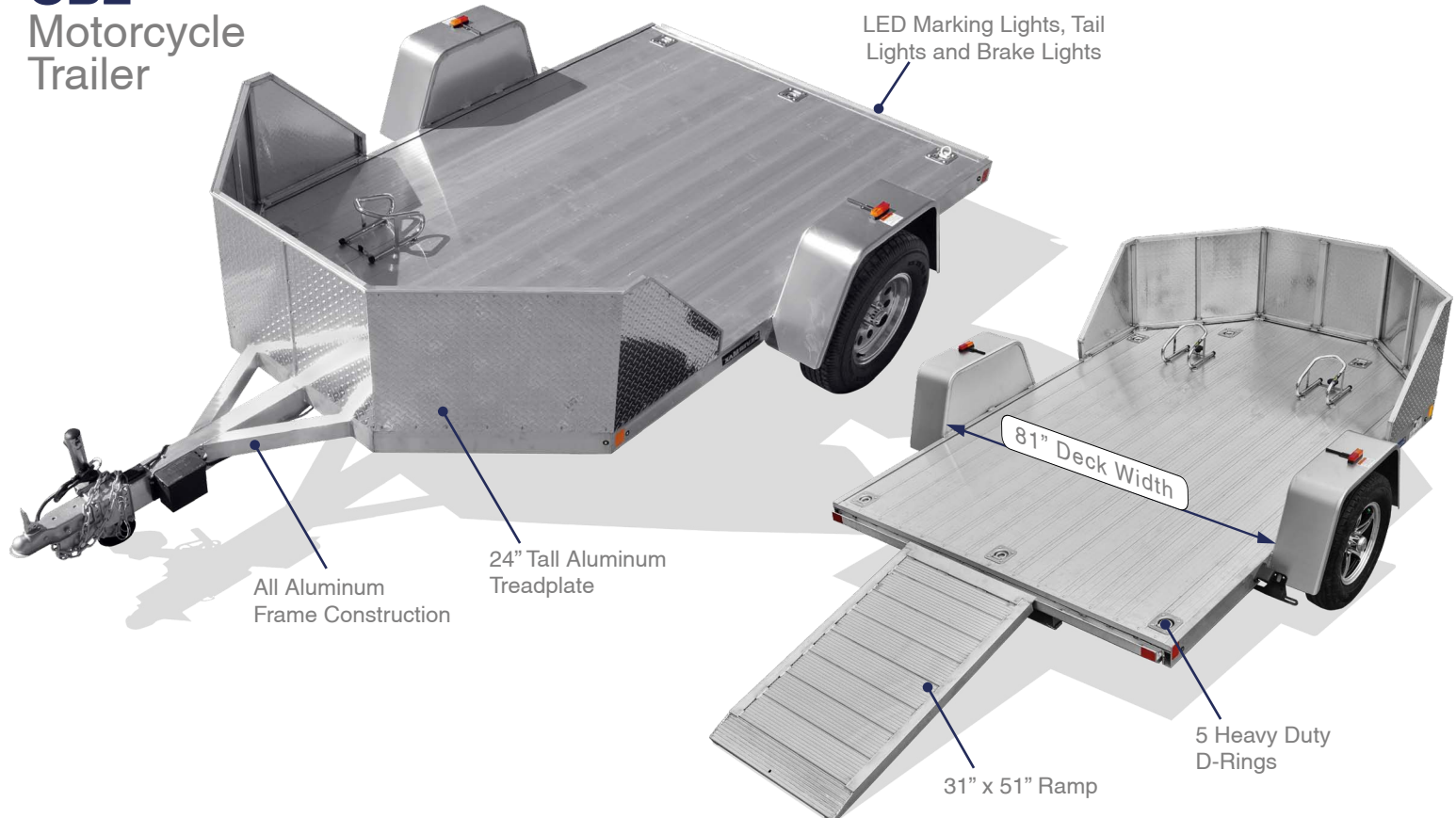



# AMT OATV Open Quad Hauler

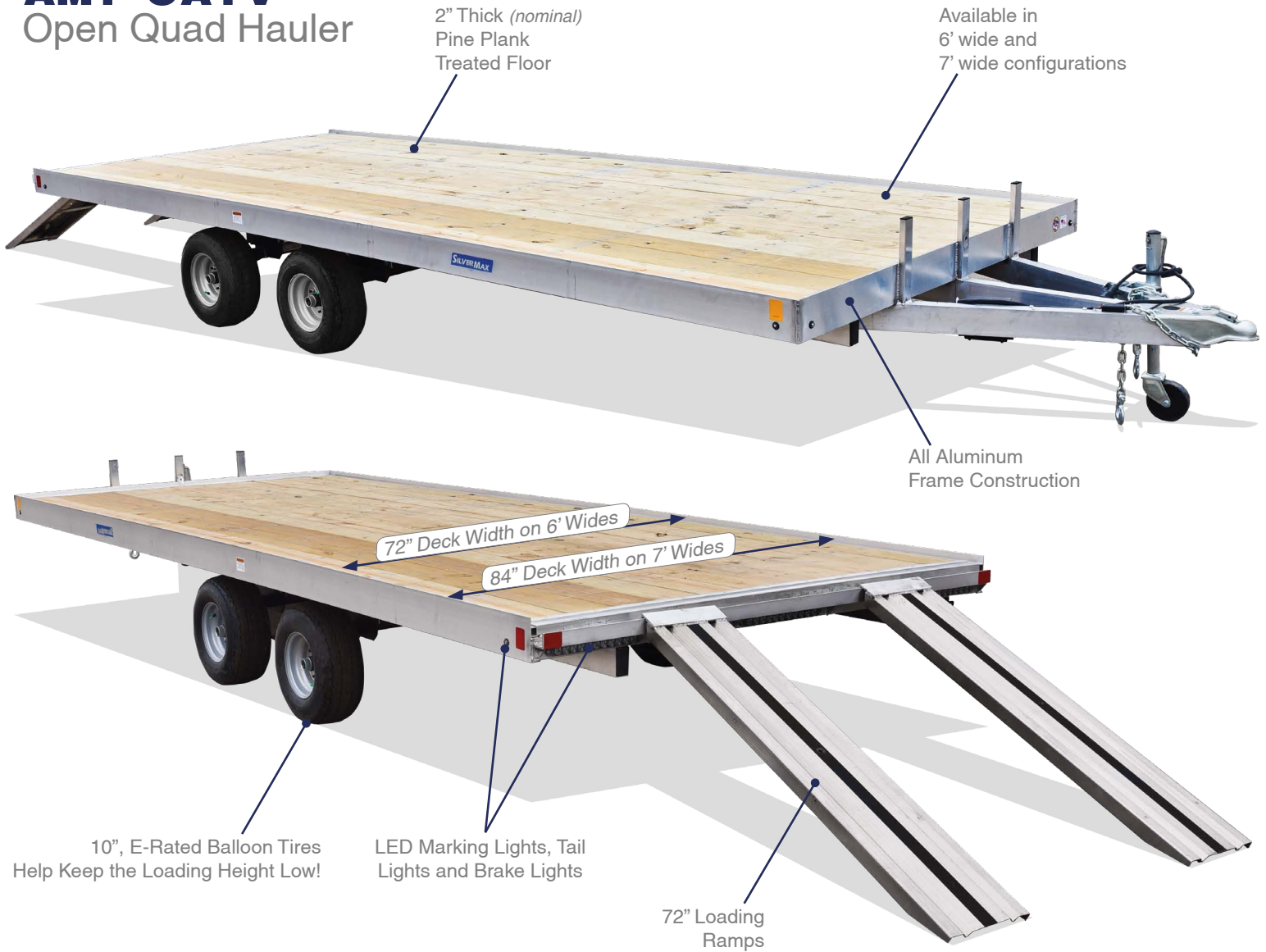

## OPTIONAL WHEELS

Take your trailer to the next level with your choice of sporty wheels!



Aluminum Mod



Series 14

Middlebury Trailers is a proud member of the National Association of Trailer Manufacturers



# Standards and Specifications

	Smooth Loader XM	Smooth Loader XE	AMCH	AMCH Deck Over	OB1	OB2	AMT OATV	
<b>Hitch</b>								
Coupler With Safety Chains	2-5/16"	2-5/16"	2-5/16"	2-5/16"	2"	2"	2" <sup>4</sup>	
6" Underslung Tongue	No	No	No	Yes	No	No	No	
Tongue Jack or Front Jack Capacity	7,000 lb.	7,000 lb.	2,000 lb.	2,000 lb.	1,000 lb.	1,000 lb.	1,000 lb.	
<b>Axle and Brakes</b>								
Spring or Torsion Axles Depending	Either	Either	Spring	Spring	Torsion	Torsion	Torsion	
Electric Brakes	Yes	Yes	Yes	Yes	No	Yes	Some Models <sup>3</sup>	
<b>Tires and Rims</b>								
20.5 X 8-10 LRE Bias Ply Tires	N/A	N/A	N/A	N/A	N/A	N/A	Yes	
ST205/75R15 C Rated Radial Tires For Single Axle	N/A	N/A	N/A	N/A	Yes	Yes	No	
ST205/75R15 C Rated Radial Tires For TA2 Axles	Yes	Yes	Yes	Yes	No	No	No	
ST225/75R15 D Rated Radial Tires For TA3 Axles	Yes	Yes	Yes	Yes	No	No	No	
ST235/80R16 E Rated Radial Tires For TA4 Axles	Yes	Yes	Yes	Yes	No	No	No	
<b>Frame</b>								
All Aluminum Frame Construction	Yes	Yes	Yes	Yes	Yes	Yes	Yes	
24" Beavertail on 18' and Longer Models	No	No	Yes	No	No	No	No	
7" Tall Aluminum Tube "Headache" Rack	Yes	Yes	Yes	No	No	No	No	
Heavy Duty D-Rings or Rope Ties	Opt	Opt	4 D-Rings	Opt	4 D-Rings	7 D-Rings	6 Rope Ties	
Stake Pockets with Rub Rail	Yes	Yes	Yes	Yes	No	No	No	
2" Thick (nominal) Pine Plank Treated Floor	Yes	Yes	Yes	Yes	No	No	Yes	
Extruded Aluminum Floor	Opt	Opt	Opt	Opt	Yes	Yes	No	
<b>Exterior</b>								
Deck Width	82"	82"	81"	98"	43"	81"	72" or 84"	
Deck Height (approximate) <sup>1</sup>	24" <sup>2</sup>	24" <sup>2</sup>	23" <sup>2</sup>	33-1/2" <sup>2</sup>	16-1/2"	16-1/2"	26-1/2"	
Removable Fenders	Yes	Yes	Yes	No Fenders	No	No	No Fenders	
<b>Electrical</b>								
LED Tail Lights, Brake Lights, and Marking Lights	•	•	•	•	•	•	•	
4-Way, or 7-Way Plug for 3,000 lb GVWR and up	•	•	•	•	•	•	•	
Breakaway Box, Battery and Switch	•	•	•	•	•	•	•	
Hydraulic Pump w/12-Volt Deep Cycle Battery	No	Yes	N/A	N/A	N/A	N/A	N/A	

<sup>1</sup> For general reference only. Deck heights will vary depending on axle capacity, axle type and tire sizes.

<sup>2</sup> For models with TA2 axles (Tandem 3,500 lb. axles)

<sup>3</sup> Yes, on Tandem Axle Models

<sup>4</sup> 2-5/16" on Tandem Axle Models

Available Sizes			
	TA2	TA3	TA4
<b>Smooth Loader XM (Manual) or XE (Electric)</b>			
18'	•	•	•
20'	•	•	•
22'	•	•	•
24'	•	•	•
<b>AMCH - Car Hauler</b>			
18'	•	•	•
20'	•	•	•
22'	•	•	•
24'	•	•	•
<b>AMCHDO - Deck Over</b>			
16'	•	•	
18'	•	•	
20'	•	•	

Available Sizes		
	Single Axle	Tandem Axle
<b>OB1 &amp; OB2 - Motorcycle Trailers</b>		
4.5'x10' OB1	•	
8.5'x11' OB2		
<b>AMT OATV - 6' Wide, 7' Wide</b>		
6'x8'	•	
6'x10'	•	
6'x12'	•	•
6'x14'		•
6'x16'		•
7'x12'		•
7'x14'		•
7'x16'		•
7'x18'		•

3-year Limited Warranty.  
See your dealer for details!

Your Professional MTI Dealer is:

